

This document involves CONFIDENTIAL proprietary design rights of HEWITT IND. and all designs, manufacturing, reproduction, use and sale rights regarding same are expressly reserved. It is submitted under a confidential relationship and the recipient agrees to assume custody and control thereof and that proprietary information contained herein shall not be reproduced or transferred to other documents or disclosed to others or used for manufacturing or any other purpose without prior written permission of HEWITT IND.

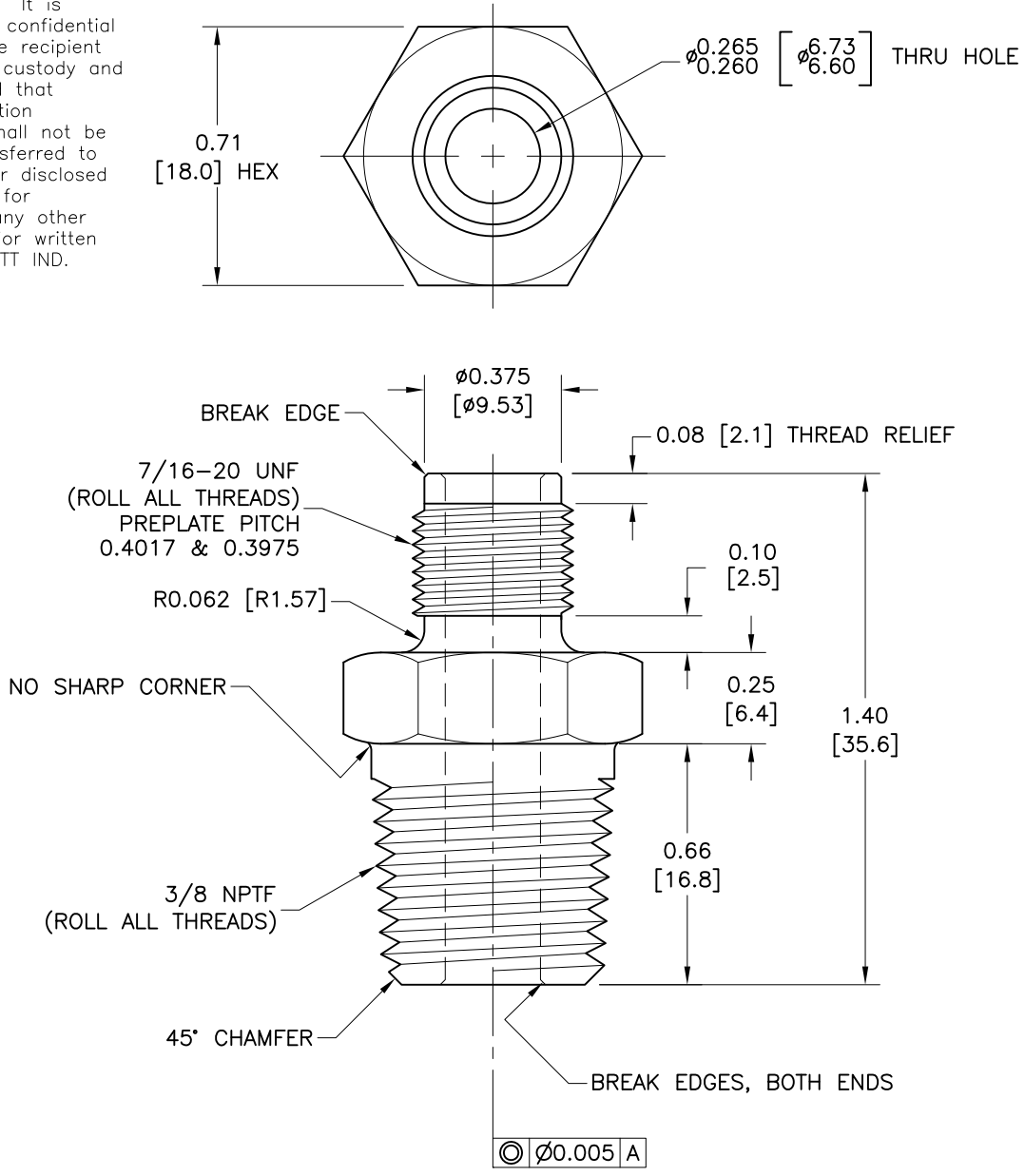

NOTES:

1. MATERIAL: 303 STAINLESS STEEL.

3/8 NPTF - 7/16-20 UNF
THERMOCOUPLE

REVISIONS					TOLERANCES		HEWITT INDUSTRIES OF LOS ANGELES	
REV.	DESCRIPTION	EO#	DATE	BY	UNLESS OTHERWISE SPECIFIED:		TITLE:	
					DIMENSIONS ARE IN INCHES, METRIC EQUIVALENTS ARE IN [BRACKETS]:		FITTING	
					.X = .030 [0.76]		DRAWN BY: JAG	
					.XX = .010 [0.25]		PART NO. 063-003	
					.XXX = .005 [0.13]		APPR. BY: DW	
					FRACTIONS = 1/32		DATE: 07/25/11	
					ANGLES = ±1°		SHEET 1 OF 1	
					SCALE: 2/1			

D