

PART NO. 024-604

DUAL MAGNETIC SENSOR
(1000 OHMS)

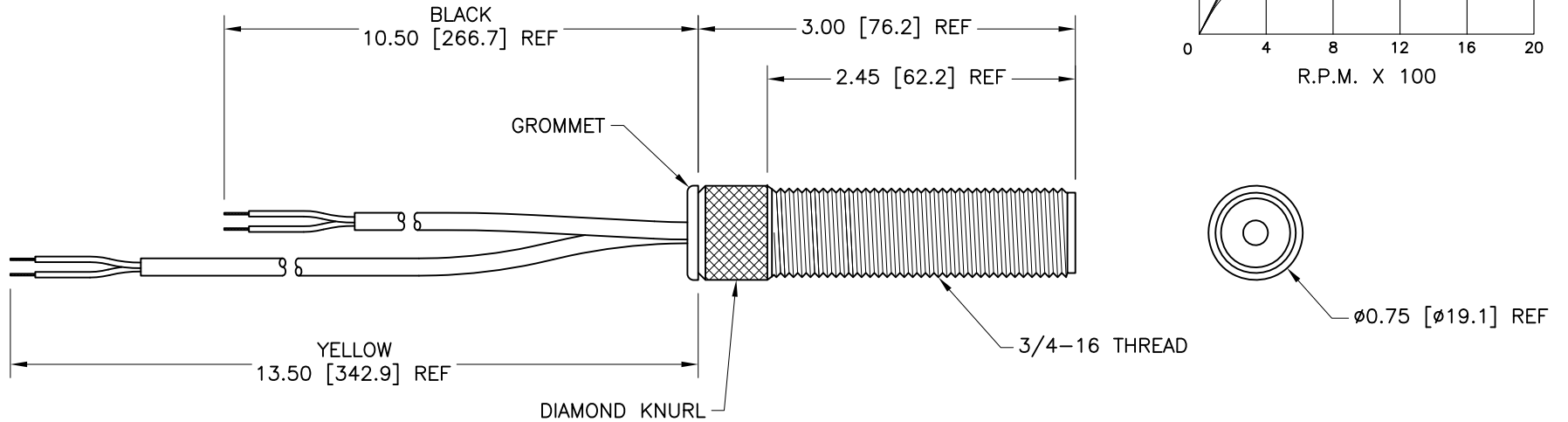
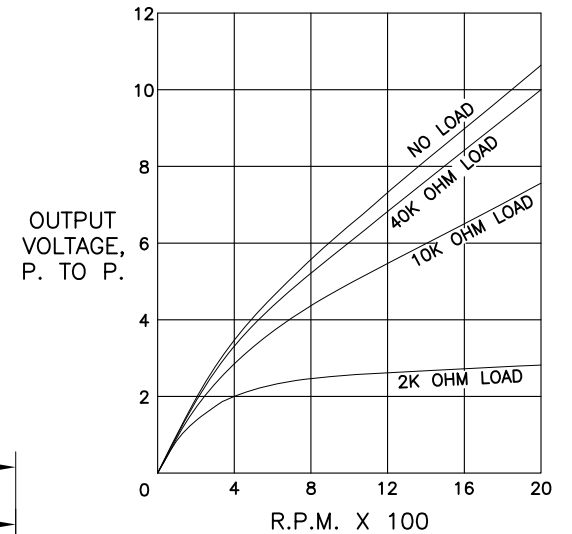

NOTES:

1. HOUSING MATERIAL: T304 STAINLESS STEEL.
2. RECOMMENDED GAP: 0.050" [1.27mm] (3/4 TURN).
3. MAXIMUM INSTALLATION TORQUE: 30FT-LBS.
4. HARDWARE: HEX NUT AND WASHER IN SEPARATE PACK.
5. BUTT CONNECTORS IN SEPARATE PACK.
6. REFERENCE FORBOY P/N 8912.

C

REVISIONS					TOLERANCES	
REV.	DESCRIPTION	EO#	DATE	BY	UNLESS OTHERWISE SPECIFIED:	
A	REVISED PER ECO #	ECO 403	03/21/08	EGM	DIMENSIONS ARE IN INCHES, METRIC EQUIVALENTS ARE IN [BRACKETS]:	
B	REVISED PER ECO #	ECO 610	09/11/12	JAG	.X = .030 [0.76]	
C	REVISED PER ECO #	ECO 613	10/04/12	JAG	.XX = .010 [0.25]	
					.XXX = .005 [0.13]	
					FRACTIONS = 1/32	
					ANGLES = ±1°	
					SCALE: 3/4	

HI HEWITT INDUSTRIES OF LOS ANGELES

TITLE: DUAL MAGNETIC SENSOR
 DRAWN BY: E. MARIANO PART NO. 024-604
 APPR. BY: D. WISHART
 DATE: 03/21/08 SHEET 1 OF 1