

PART NO. 024-071

SINGLE MAGNETIC SENSOR  
(520 OHMS)

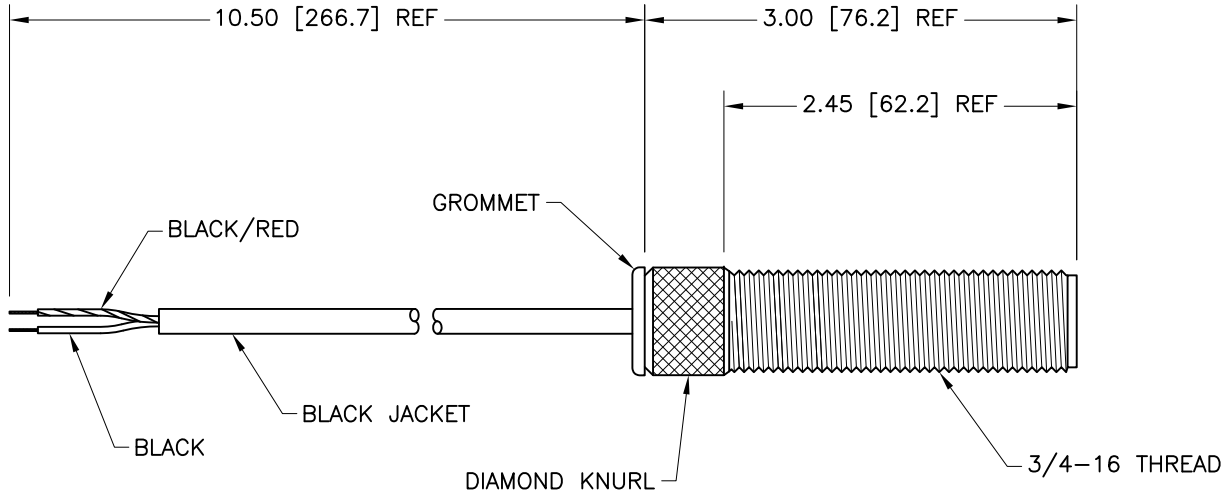
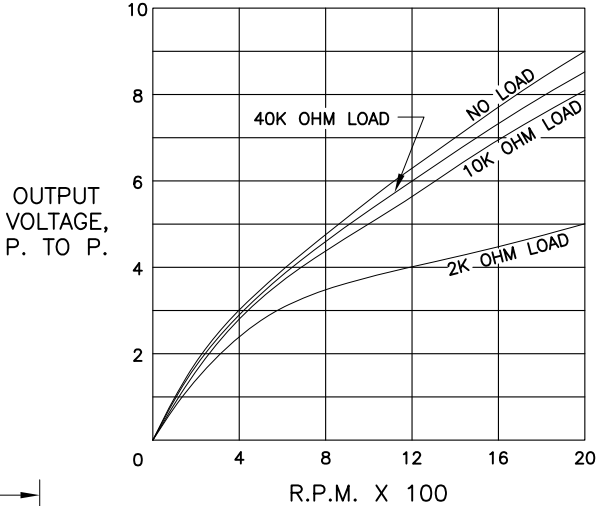

NOTES:

1. HOUSING MATERIAL: T304 STAINLESS STEEL.
2. RECOMMENDED GAP: 0.050" [1.27mm] (3/4 TURN).
3. MAXIMUM INSTALLATION TORQUE: 30FT-LBS.
4. HARDWARE: HEX NUT AND WASHER IN SEPARATE PACK.
5. BUTT CONNECTORS IN SEPARATE PACK.
6. REFERENCE FIRBOY P/N 8910.

C

REVISIONS					TOLERANCES		HEWITT INDUSTRIES OF LOS ANGELES	
REV.	DESCRIPTION	EO#	DATE	BY	UNLESS OTHERWISE SPECIFIED:		TITLE:	
A	REVISED PER ECO #	ECO 403	03/21/08	EGM	DIMENSIONS ARE IN INCHES, METRIC EQUIVALENTS ARE IN [BRACKETS]:		SINGLE MAGNETIC SENSOR	
B	REVISED PER ECO #	ECO 610	09/11/12	JAG	.X = .030 [0.76]		DRAWN BY:	PART NO.
C	REVISED PER ECO #	ECO 613	10/04/12	JAG	.XX = .010 [0.25]		APPR. BY:	024-071
					.XXX = .005 [0.13]		DATE:	SHEET 1 OF 1
					FRACTIONS = 1/32			
					ANGLES = ±1°			
					SCALE:	3/4		