

PART NO. 102-102-XX-X

PART NO.	DIAL FACE COLORS
102-102-1X-X	BLACK BACKGROUND, WHITE CHARACTERS, WHITE ILLUMINATION
102-102-2X-X	WHITE BACKGROUND, BLACK CHARACTERS, GREEN ILLUMINATION
102-102-3X-X	BLACK BACKGROUND, WHITE CHARACTERS, RED ILLUMINATION
102-102-4X-X	BLACK BACKGROUND, WHITE CHARACTERS, GREEN ILLUMINATION

PART NO.	POINTER COLOR
102-102-XB-X	BLACK
102-102-XR-X	RED
102-102-XW-X	WHITE

PART NO.	BEZEL STYLE
102-102-XX-1	BLACK
102-102-XX-2	POLISHED
102-102-XX-3	WHITE
102-102-XX-4	BLACK, AIRCRAFT

102-102-XX-X

DIAL FACE COLORS  
 POINTER COLOR  
 BEZEL COLOR & STYLE



P/N 102-102-2R-1  
SCALE: 3/4



P/N 102-102-1R-1



P/N 102-102-3W-1  
SCALE: 3/4



P/N 102-102-4R-2  
SCALE: 3/4

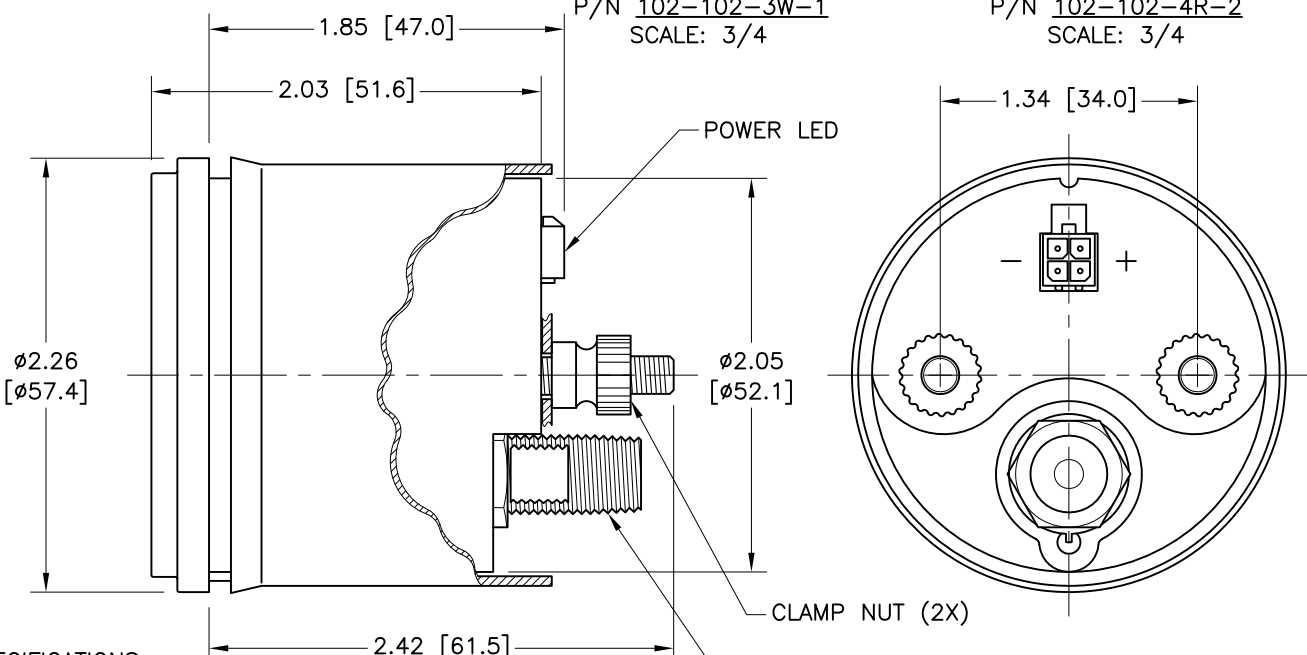

**SPECIFICATIONS:**

- DIAL:  
SCALE: 270° ARC SWEEP.  
RANGE: 0 - 50 PSI.
- ILLUMINATION:  
INTERNAL 12 VDC (24 VDC ALSO AVAILABLE).  
ILLUMINATED POINTER AND L.E.D. BACKLIT DIAL.
- POINTER COLOR:  
STANDARD: RED FLUORESCENT (SEE TABLE).

REVISIONS					TOLERANCES	
REV.	DESCRIPTION	EO#	DATE	BY	UNLESS OTHERWISE SPECIFIED:	
1	ENGINEERING RELEASE	-	07/22/10	JAG	DIMENSIONS ARE IN INCHES, METRIC TOLERANCES ARE IN [BRACKETS]:	
2	REMOVED TAIL FROM POINTER	-	03/14/11	JAG	.X = .050 [1.27]	
3	ADDED GRAPHICS FOR DIAL COLOR & BEZEL CHOICES	-	08/19/11	JAG	.XX = .030 [0.76]	
A	NEW RELEASE PER ECO	ECO 582	02/08/12	JAG	.XXX = .010 [0.25]	
					FRACTIONS = 1/32	
					ANGLES = ±1°	
					SCALE: 1/1	

**HI HEWITT INDUSTRIES OF LOS ANGELES**

TITLE: 2" TURBO BOOST PRESSURE GAUGE

DRAWN BY: J.GUERRERO PART NO. 102-102-XX-X

APPR. BY: D.WISHART

DATE: 07/22/10 SHEET 1 OF 1

A