

PART NO. 011-103-XX-X

PART NO.	DIAL FACE COLORS
011-103-1X-X	BLACK BACKGROUND, WHITE CHARACTERS, WHITE ILLUMINATION
011-103-2X-X	WHITE BACKGROUND, BLACK CHARACTERS, GREEN ILLUMINATION
011-103-3X-X	BLACK BACKGROUND, WHITE CHARACTERS, RED ILLUMINATION
011-103-4X-X	BLACK BACKGROUND, WHITE CHARACTERS, GREEN ILLUMINATION

PART NO.	POINTER COLOR
011-103-XB-X	BLACK
011-103-XR-X	RED
011-103-XW-X	WHITE

PART NO.	BEZEL STYLE
011-103-XX-1	BLACK
011-103-XX-2	POLISHED
011-103-XX-3	WHITE
011-103-XX-4	BLACK, AIRCRAFT



P/N 011-103-2R-1
SCALE: 3/4



P/N 011-103-1R-1

DIAL FACE COLORS
POINTER COLOR
BEZEL COLOR & STYLE



P/N 011-103-3W-1
SCALE: 3/4



P/N 011-103-4R-2
SCALE: 3/4

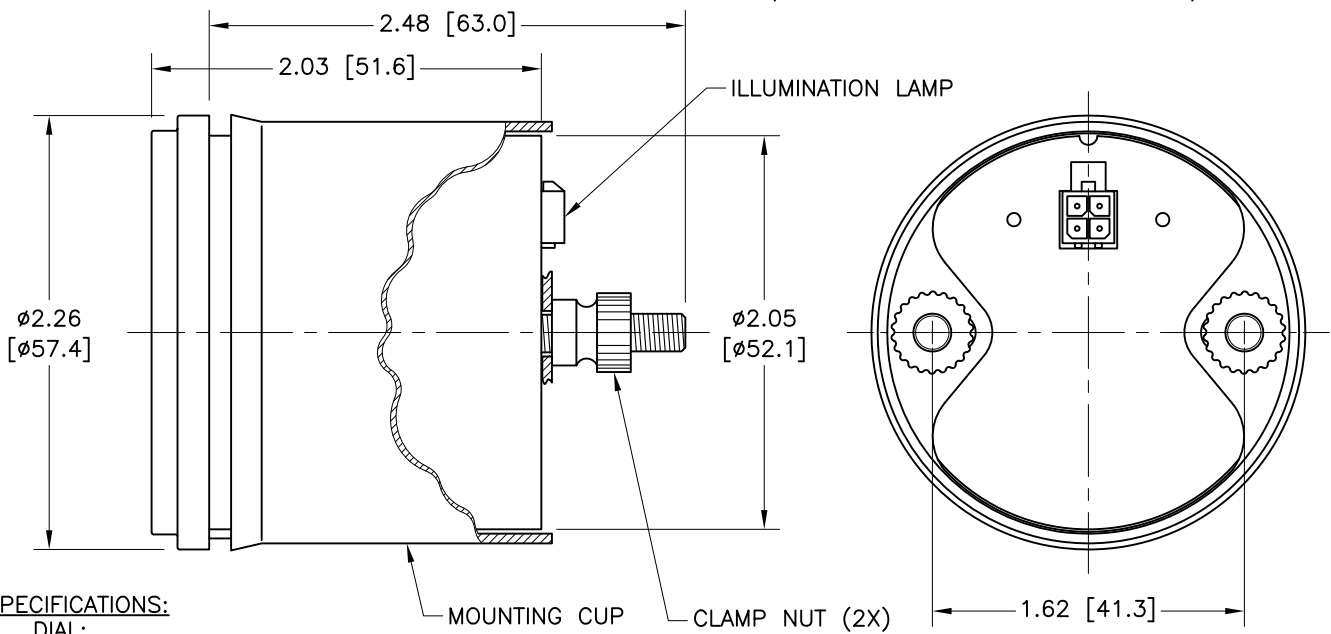

SPECIFICATIONS:

- DIAL:
SCALE: ARC 100° SWEEP.
RANGE: 140°F - 320°F.
- ILLUMINATION:
INTERNAL 12 VDC (24 VDC ALSO AVAILABLE).
ILLUMINATED POINTER AND L.E.D. BACKLIT DIAL.
- POINTER COLOR:
STANDARD: RED FLUORESCENT (SEE TABLE).
- MOVEMENT:
AIRCORE.

REVISIONS					TOLERANCES	
REV.	DESCRIPTION	EO#	DATE	BY	UNLESS OTHERWISE SPECIFIED:	
A	PRODUCTION RELEASE PER ECO #	ECO 472	08/29/09	JAG	DIMENSIONS ARE IN INCHES, METRIC TOLERANCES ARE IN [BRACKETS]:	
B	REVISED PER ECO #	ECO 530	02/04/11	JAG	.X = .050 [1.27]	
C	REVISED PER ECO #	ECO 537	03/14/11	JAG	.XX = .030 [0.76]	
D	REVISED PER ECO #	ECO 563	08/24/11	JAG	.XXX = .010 [0.25]	
E	REVISED PER ECO #	ECO 581	02/23/12	JAG	FRACTIONS = 1/32	
					ANGLES = ±1°	
					SCALE: 1/1	

HI HEWITT INDUSTRIES OF LOS ANGELES

TITLE: 2" TRANSMISSION OIL TEMPERATURE GAUGE

DRAWN BY: J.GUERRERO PART NO. 011-103-XX-X

APPR. BY: L.MAGANA

DATE: 08/29/09 SHEET 1 OF 1

E